

MTA SERIES

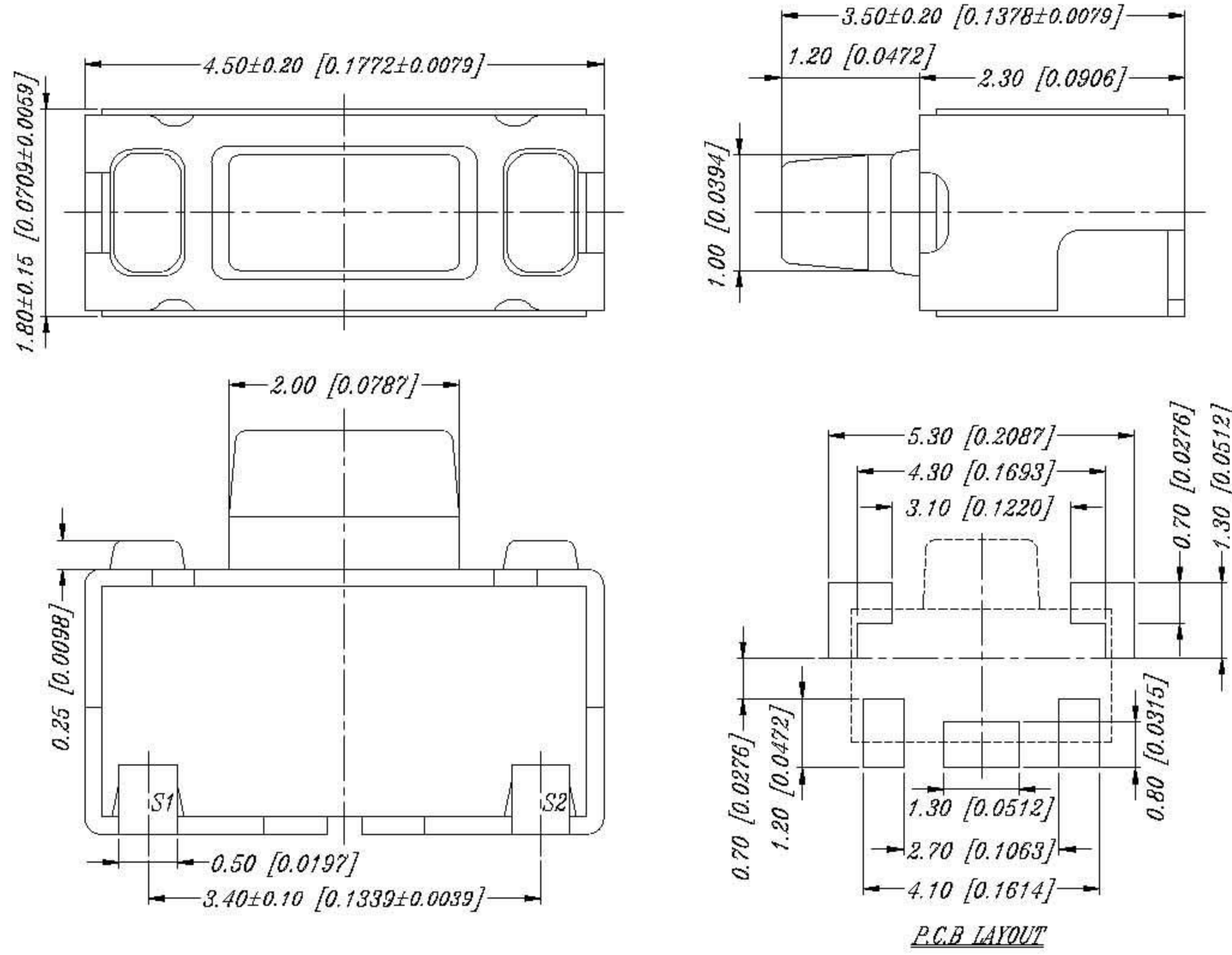

DIMENSION

MTA-N



General Tolerance : $\pm 0.2\text{mm}$

MTA-NC

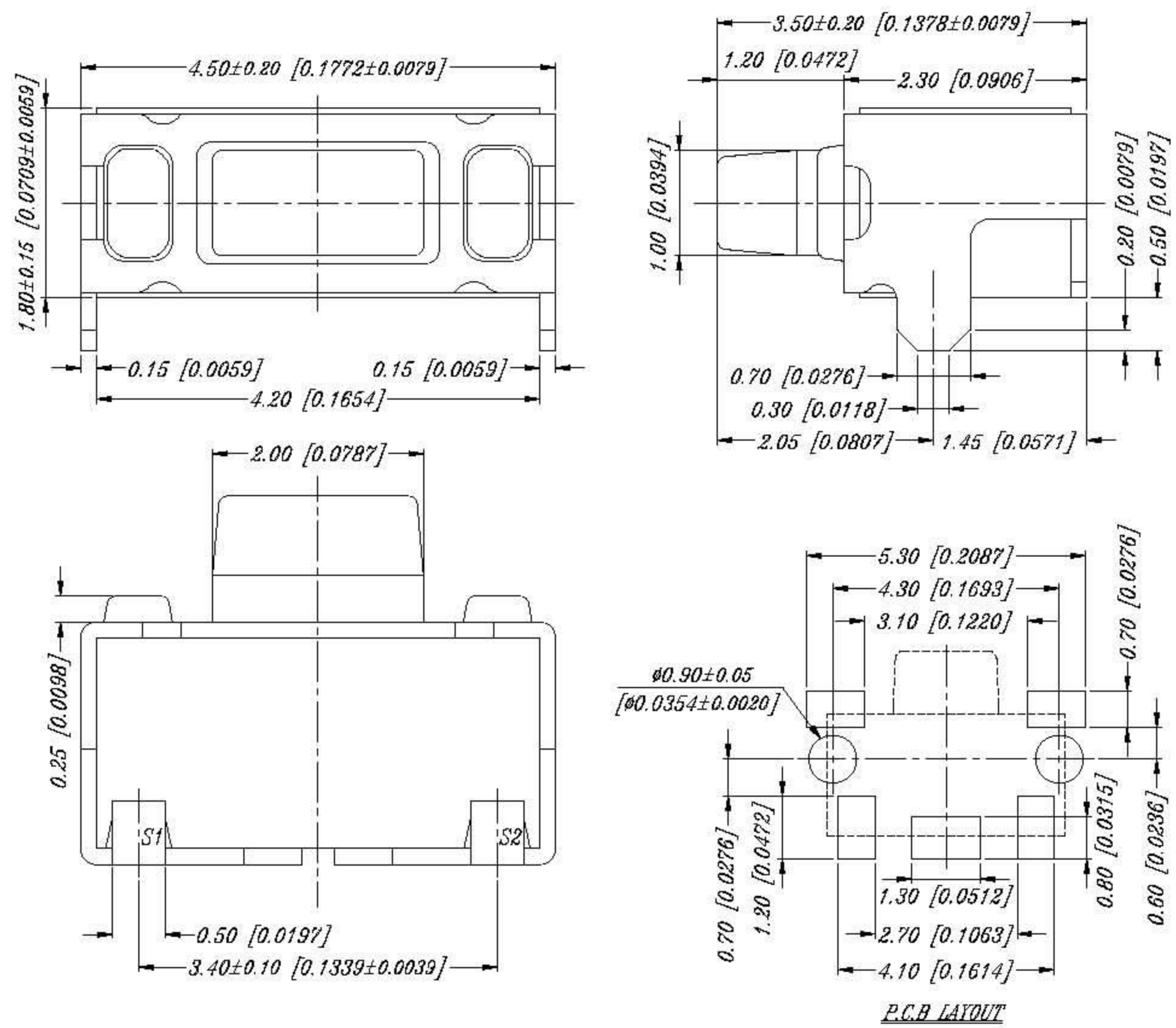

General Tolerance : $\pm 0.2\text{mm}$

MTA-WN

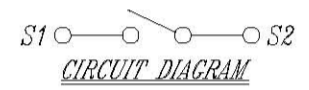
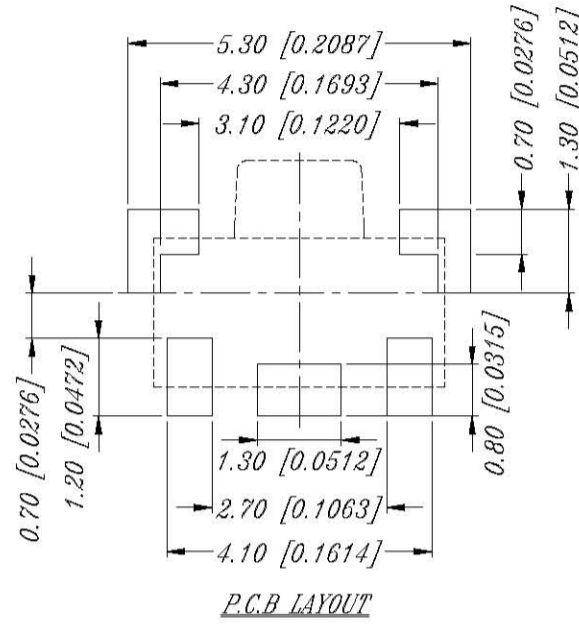
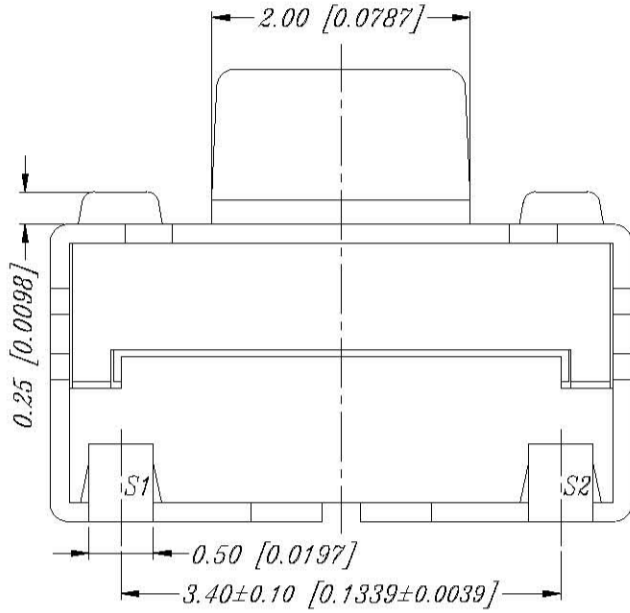
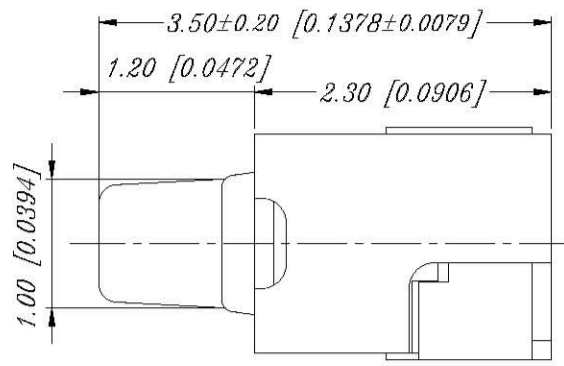
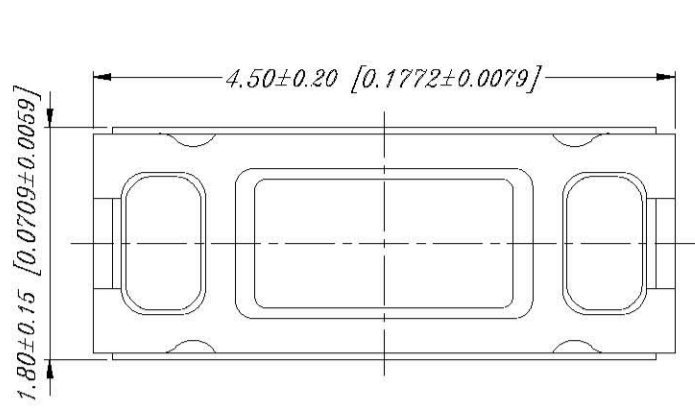

P.C.B LAYOUT

General Tolerance : ±0.2mm

MTA-WNC

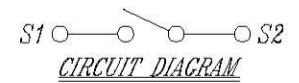
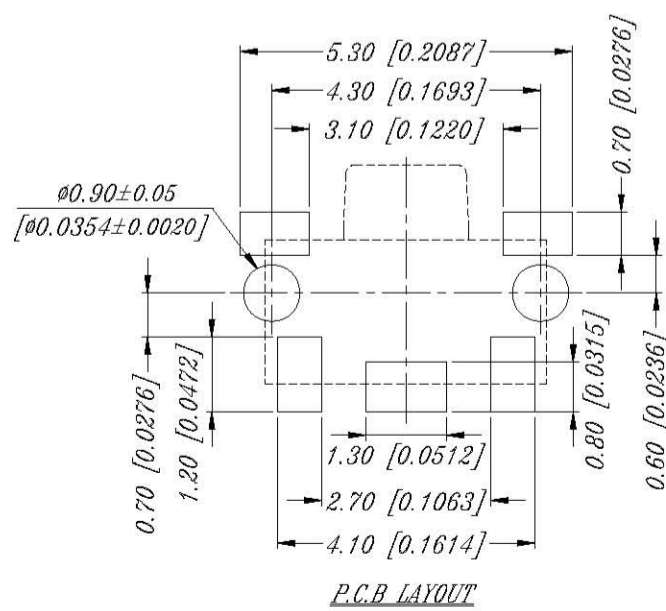
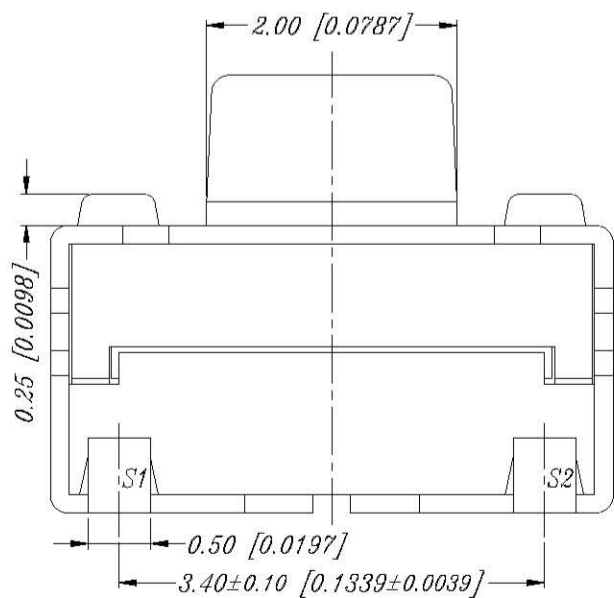
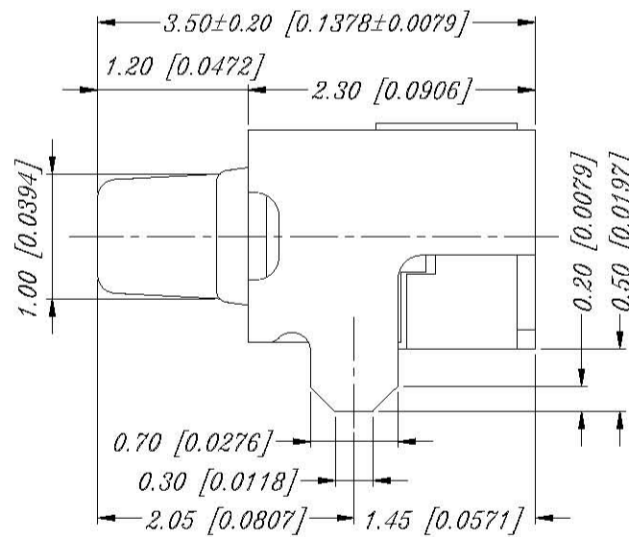
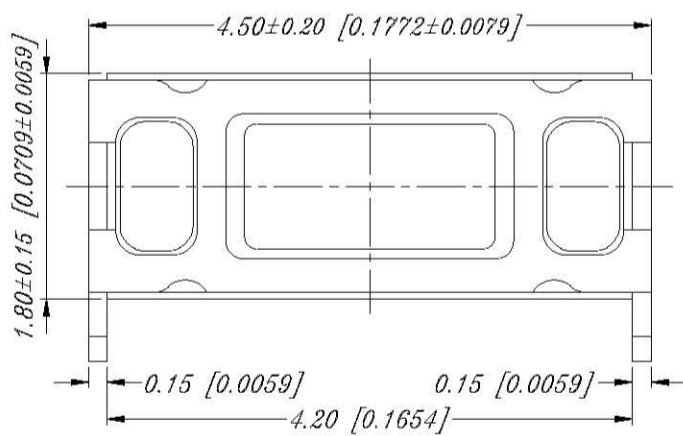

P.C.B LAYOUT

General Tolerance : ±0.2mm

HOW TO ORDER

M T A - □ □ □ - V - □

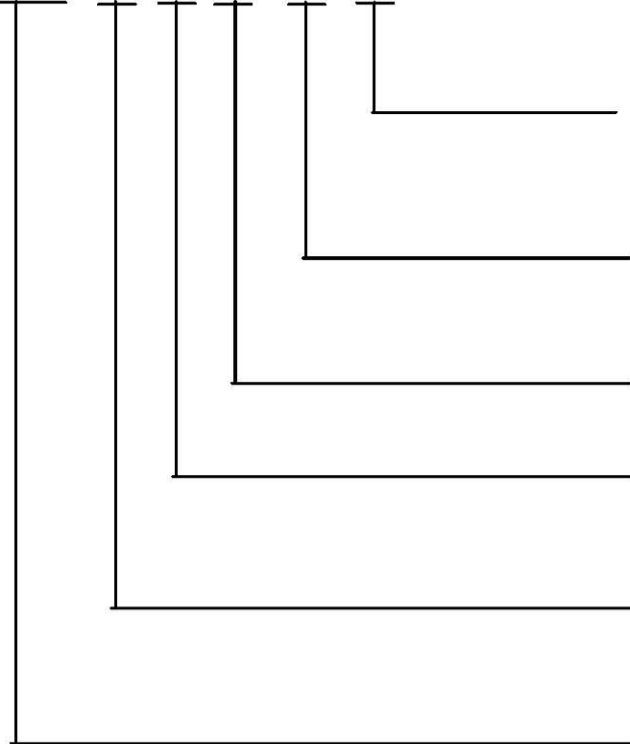

Package Style :
T/R = Tape & Reel

Soldering :
V = Lead Free Solderable

C = With Post

Color Of Stem For Operating Force :
N = Brown, 160gf

W = Washable Type
□ = Non-Washable Type

Right Angle Type

SPECIFICATION

△MECHANICAL

Mechanical Life : 50,000 cycles
Operation Force : 160±50gf
Stroke : 0.2±0.1mm

△ENVIRONMENTAL

Operation Temperature Range : -30°C to +80°C
Storage Temperature Range : -40°C to +90°C

△ELECTRICAL

Electrical Life: 50,000 cycles
Switching Rating: 50 mA, 12 VDC

MATERIALS

△COVER : Nickel Silver

△BLOCK : PA9T High-temp Thermoplastic
Color : Black

△STEM : PA9T High-temp Thermoplastic
Color : Brown

△ADHESIVE TYPE : Kapton

△CONTACT : Stainless steel

△BASE : PA9T High-temp Thermoplastic
Color : Black

△TERMINAL : Brass with silver plating

SOLDERING PROCESS

△HAND SOLDERING : Us a soldering iron of 30 watts, controlled at 350°C approximately 5 seconds while applying solder.

△REFLOW SOLDERING : When applying reflow soldering, the peak temperature or the reflow over should be set to 260°C max.

△TEMPERATURE PROFILE :

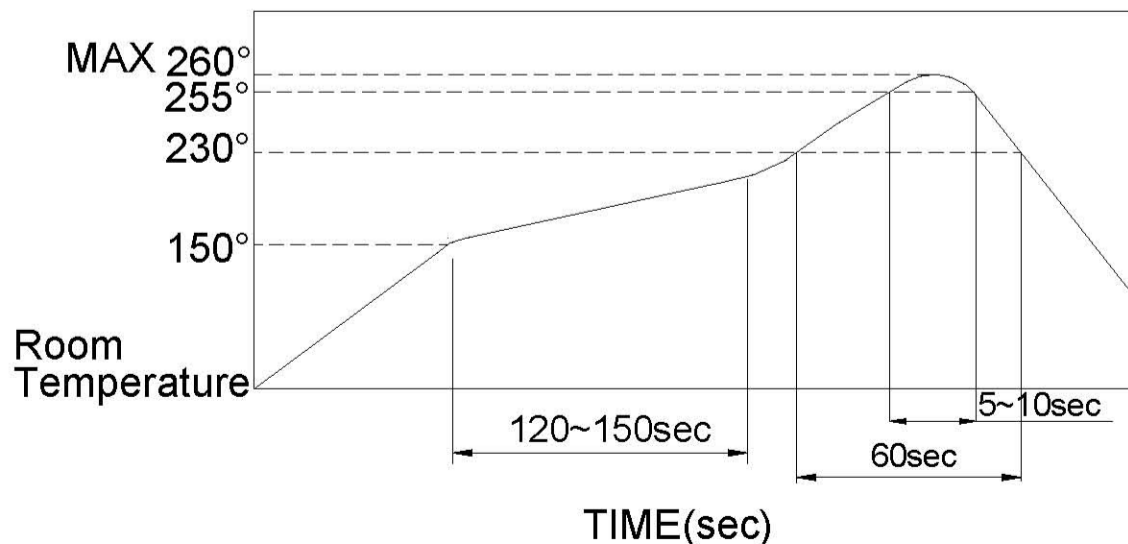

PACKING

REEL

Part Number	Number Per Reel	Number Per Tube
MTA-N	4000	—
MTA-NC	4000	—
MTA-WN	4000	—
MTA-WNC	4000	—

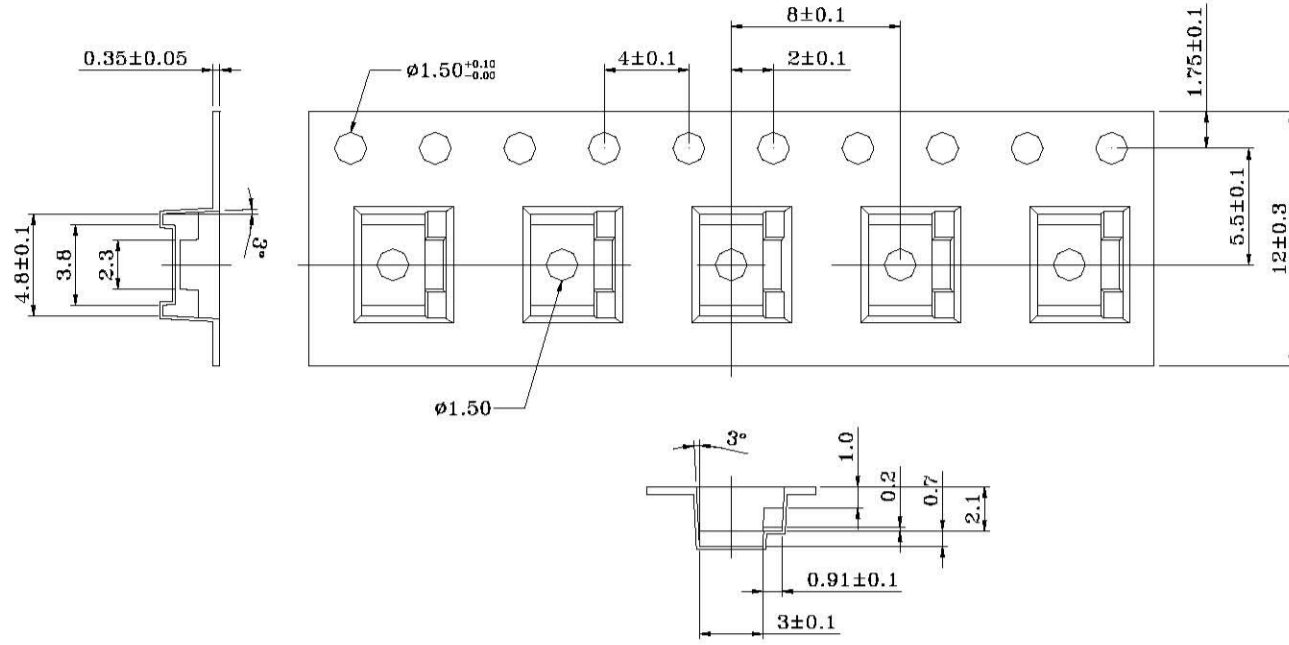

General Tolerance : $\pm 0.2\text{mm}$